



Model PR-243

Technical Information

TI.243-02

7400 Flying Cloud Drive • Minneapolis, MN 55344-3720 • USA
800-843-5116 • 952-835-1626 • Fax 952-829-5331
tech@mamacsys.com • www.mamacsys.com

Pneumatic Pressure Transducer

FOR ADDITIONAL INFORMATION
SEE PR-243 DATA SHEET

SPECIFICATIONS

Accuracy*: $\pm 1\%$ FS

Maximum Pressure: 40 psig

Supply Voltage 12-40 VDC
12-35 VAC (VDC output units only)

Supply Current: VDC Units - 10 mA max.
mA Units - 20 mA max.

Enclosure: 18 Ga C. R. Steel NEMA 4 (IP-65)

Finish: Baked on enamel-PMS2GR88B

Conformance: EMC Standards EN50082-1(1992)
EN55014(1993)/EN60730-1(1992)

Compensated Temp Range: 0°F-180°F (-18°C-82°C)

T. C. Error: $\pm 0.025\%/^{\circ}\text{F}$ (.03%/°C)

Media Compatibility: Dry air or inert gases

Port Connection: 5/32" I.D., 1/4" OD Hose Barb

Environmental: 10-90%RH Non-Condensing

Termination: Unpluggable screw terminal block

Wire Size: 12 Ga max.

Load Impedance: 1.6K ohms max. at 40 VDC (mA output units)
1K ohms min. (VDC output units)

Weight: 1.0 lbs. (.45 kg)

*Includes non-linearity, hysteresis and non-repeatability

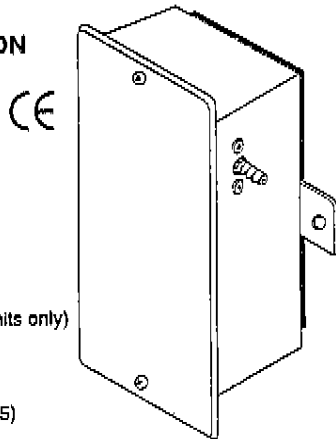

INSTALLATION

Inspection Inspect the package for damage. If damaged, notify the appropriate carrier immediately. If undamaged, open the package and inspect the device for obvious damage. Return damaged products.

- Requirements**
- Tools (not provided)
 - Digital Volt-ohm Meter (DVM)
 - Appropriate screwdriver for mounting screws
 - Appropriate drill and drill bit for mounting screws
 - Appropriate accessories
 - Two #8 self-tapping mounting screws (not provided)
 - Training: Installer must be a qualified, experienced technician

Warning:

- Do not use on oxygen service, in an explosive/hazardous environment, or with flammable/combustible media.
- Disconnect power supply before installation to prevent electrical shock and equipment damage.
- Make all connections in accordance with the job wiring diagram, and in accordance with national and local electrical codes. Use copper conductors only.



Caution:

- Use electrostatic discharge precautions (e.g., use of wrist straps) during installation and wiring to prevent equipment damage.
- Avoid locations where severe shock or vibration, excessive moisture or corrosive fumes are present. NEMA Type 4 housings are intended for outdoor use primarily to provide a degree of protection against wind-blown dust, rain, and hose-directed water.
- Do not exceed ratings of the device.

Mounting

The PR-243 must be mounted on a vertical surface with the 1/4" brass hose barb pointing left or right. Refer to Figure-7 for mounting dimensions.

1. Remove the transducer cover using a Phillips head screwdriver.
2. Select the mounting location.
3. Mount transducer on a vertical surface with two #8 self-tapping screws (not provided).
4. Pull wires through bottom of enclosure and make necessary connections.
5. Replace cover and make pneumatic connections.

Wiring

Use maximum 12 AWG wire for wiring terminals. Use flexible 1/4" O.D., 5/32 I.D. tubing for pressure connections. Refer to Figures 1, 2, 3, & 4 for wiring information and Figures 5 & 6 for jumper designations.

Wiring PR-243 Units with mA Output

PR-243 pressure transducers are 4-20 mA output units powered with a 12-40 VDC supply.

The following describes the proper wiring of these pressure transducers with mA output:

1. Remove the blue terminal block by carefully pulling it off the circuit board.
2. Locate the (+) and (-) terminal markings on the board.
3. Attach the supply voltage to the (+) lead.
4. Connect the 4-20 mA output (- terminal) to the controller's input terminal.
5. Ensure that the power supply common is attached to the common bus of the controller.
6. Re-insert the terminal block to the circuit board and apply power to the unit.
7. Check for the appropriate output signal using an ammeter set on DC milliamps connected in series with the (-) terminal.

RANGE	OUTPUT
-------	--------

R1 (psig) 0 TO 20 / 0 TO 10 / 0 TO 5	mA (4-20 mA 2-wire)
R2 (psig) 0 TO 30 / 0 TO 15 / 0 TO 7.5	VDC (0-5 VDC or 0-10 VDC Field Selectable)
R3 (psig) 3 TO 15	
R4 (kPa) 0 TO 140 / 0 TO 70 / 0 TO 35	
R5 (kPa) 0 TO 200 / 0 TO 100 / 0 TO 50	
R6 (kPa) 20 TO 100	

Pneumatic Pressure Transduce

PR-243 Pressure Transducers with mA Output.

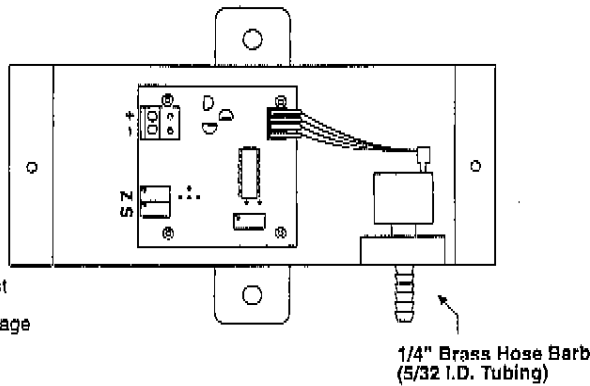

Legend
 S = Span Adjust
 Z = Zero Adjust
 + = Supply Voltage
 - = Output

Wiring PR-243 Units with VDC Output

PR-243 pressure transducers with VDC output are field selectable 0-5 VDC or 0-10 VDC output and can be powered with either 12-40 VDC or 12-35 VAC. The following describes the proper wiring of these pressure transducers with VDC output:

1. Remove the blue terminal block by carefully pulling it off the circuit board.
2. Locate the (+), (-), and (0) terminal markings on the board.
3. Attach the power wires to the (+) and (-) terminals. The (-) terminal is also the negative output terminal.
4. Connect the (0) terminal, which is the positive VDC output terminal, to the controller's input terminal.
5. Re-insert the terminal block to the circuit board and apply power to the unit.
6. Check the appropriate VDC output using a voltmeter set on DC volts across the (0) and (-) terminals.

Note: If you are using grounded AC, the hot wire must be on the (+) terminal. Also, if you are using a controller without built-in isolation, use an isolation transformer to supply the PR-243 transducer.

Caution: This product contains a half-wave rectifier power supply and must not be powered off transformers used to power other devices utilizing non-isolated full-wave rectifier power supplies.

Caution: When multiple PR-243 units are powered from the same transformer, damage will result unless all 24G power leads are connected to the same power lead on all devices. It is mandatory that correct phasing be maintained when powering more than one device from a single transformer.

PR-243 Pressure Transducers with VDC Output.

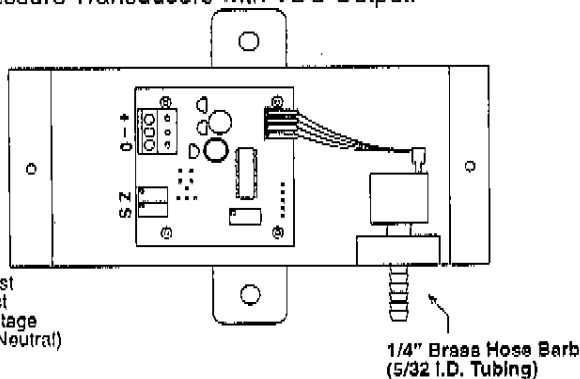

Legend
 S = Span Adjust
 Z = Zero Adjust
 + = Supply Voltage
 - = Common (Neutral)
 0 = Output

TYPICAL APPLICATIONS (wiring diagrams)

Figure-1 and Figure-2
 Illustrate typical wiring diagrams for the PR-243, 4-20 mA, two-wire output pressure transducers.

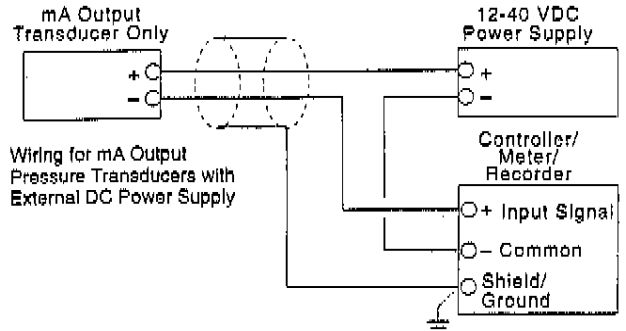

Figure-1 Wiring for mA Output Pressure Transducers with External DC Power Supply

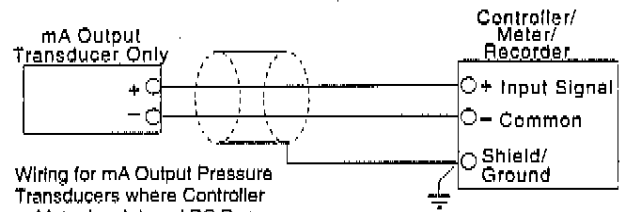

Figure-2 Wiring for mA Output Pressure Transducers where Controller or Meter has Internal DC Power Supply

Figure-3 and Figure-4
 Illustrate typical wiring diagrams for the PR-243, 0-5/0-10 VDC output pressure transducers.

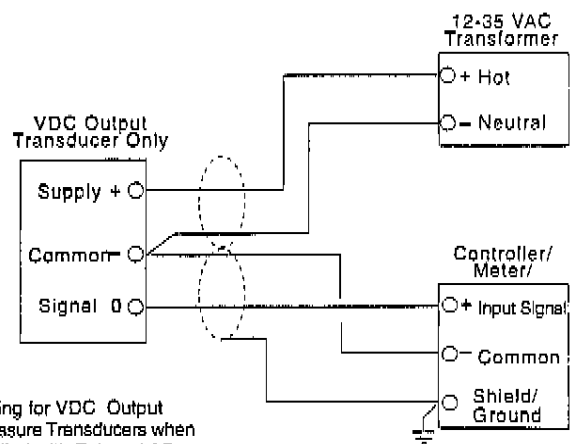

Figure-3 Wiring for VDC Output Pressure Transducers when applied with External AC Supply.

Pneumatic Pressure Transducer

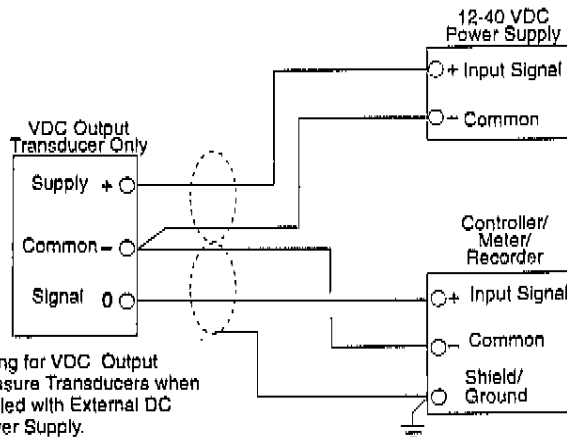

Figure-4 Wiring for VDC Output Pressure Transducers when applied with External DC Power Supply.

ADJUSTMENTS

Jumper Selection

Jumper selections vary according to the pressure transducer (mA or VDC).

The following describes the possible selections for each model.

mA Selection

Jumper Selections for PR-243 Pressure Transducers with mA Outputs

The possible range configurations and jumper selections for pressure transducers with mA outputs are shown in Table-1 and Figure-5, respectively.



Caution:

- All jumpers must be in desired position before powering unit. Never power unit without jumpers in place.
- Disconnect power before any repositioning of jumpers.

Table-1 Range Configurations for Pressure Transducers with mA Outputs

Range	Range Configurations (psig)		
	A	B	C
R1	0 to 20	0 to 10	0 to 5
R2	0 to 30	0 to 15	0 to 7.5
R3	3 to 15	---	---

Range	Range Configurations (kPa)		
	A	B	C
R4	0 to 140	0 to 70	0 to 35
R5	0 to 200	0 to 100	0 to 50
R6	20 to 100	---	---

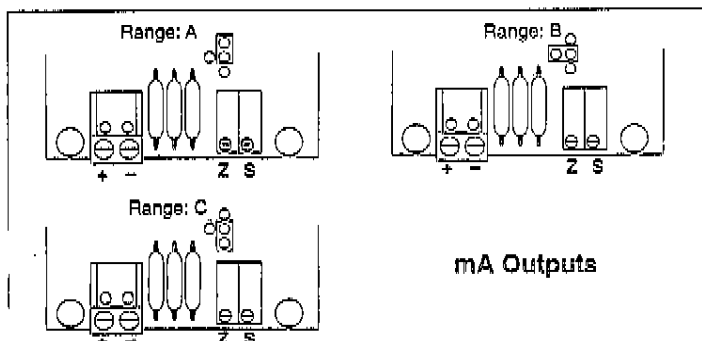

Figure-5 Jumper Selections for Pressure Transducers with mA Outputs.

VDC Selection

Jumper Selections for PR-243 Pressure Transducers with VDC Outputs

The possible range configurations and jumper selections for pressure transducers with VDC outputs are shown in Table-2 and Figure-6, respectively.



Caution:

- All jumpers must be in desired position before powering unit. Never power unit without jumpers in place.
- Disconnect power before any repositioning of jumpers.

Table-2 Range Configurations for Pressure Transducers with VDC Outputs

Range	Output Configurations	Range Configurations (psig)		
		A	B	C
R1	0 to 5 VDC	0 to 20	0 to 10	0 to 5
R2	0 to 10 VDC	0 to 30	0 to 15	0 to 7.5
R3	---	---	3 to 15	---

Range	Output Configurations	Range Configurations (kPa)		
		A	B	C
R4	0 to 5 VDC	0 to 140	0 to 70	0 to 35
R5	0 to 10 VDC	0 to 200	0 to 100	0 to 50
R6	---	---	20 to 100	---

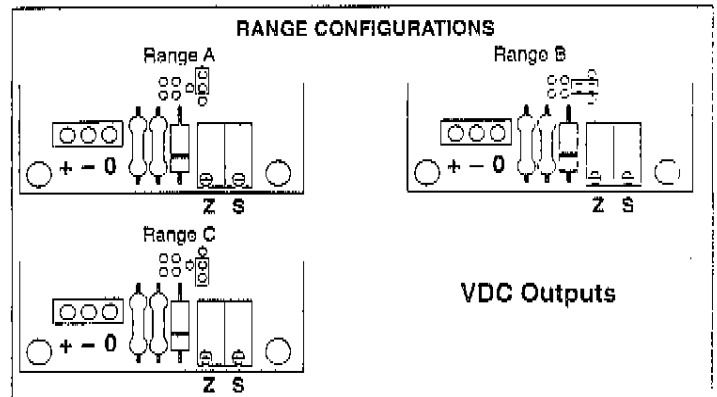
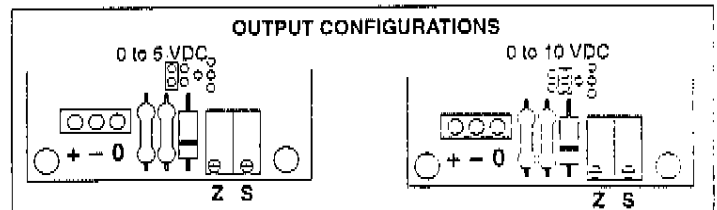

Figure-6 Jumper Selections for Pressure Transducers with VDC Outputs.

Model PR-243

Technical Information

TI.243-02

Pneumatic Pressure Transducer

- CHECKOUT**
1. Verify that the unit is mounted in the correct position.
 2. Verify appropriate input signal and supply voltage.

Caution: Never connect 120 VAC to these transducers. Never connect AC voltage to a unit intended for DC supply.

3. Verify appropriate range configuration.

- Transducer Operation**
- This is a rough functional check only.
1. Adjust the pressure to obtain maximum output signal for appropriate range.
 2. Output should be 20 mA or 5 or 10 VDC.
 3. Adjust the pressure to obtain minimum output signal.
 4. Output should be 4 mA or 0 VDC.

Note: The PR-243 is a highly accurate device. For applications requiring a high degree of accuracy, the use of laboratory quality meters and gauges are recommended.

- CALIBRATION** All units are factory calibrated to meet or exceed published specifications. If field adjustment is necessary, follow the instructions below.

Calibration of PR-243 mA Units

1. Connect terminals (+) and (-) to the appropriate power source.
2. Connect the DVM in series on the (-) terminal.
3. Apply low pressure to the unit and carefully adjust the zero trimmer (Z) to obtain desired low output.
4. Apply high pressure to the unit and adjust span trimmer (S) to obtain the desired high output.
5. Repeat steps 3 and 4 until desired calibration is achieved.

Calibration of PR-243 VDC Units

1. Connect terminals (+) and (-) to the appropriate power source. The (-) terminal is also the negative output terminal.
2. Connect the DVM on DC volts across (0) and (-) terminal.
3. Apply low pressure to the unit and carefully adjust the zero trimmer (Z) to obtain desired low output.
4. Apply high pressure to the unit and adjust span trimmer (S) to obtain the desired high output.
5. Repeat steps 3 and 4 until desired calibration is achieved.

- MAINTENANCE** Regular maintenance of the total system is recommended to assure sustained optimum performance.

- FIELD REPAIR** None. Replace with a functional unit.

- WARRANTY** See Data Sheet for additional information.

DIMENSIONAL DATA

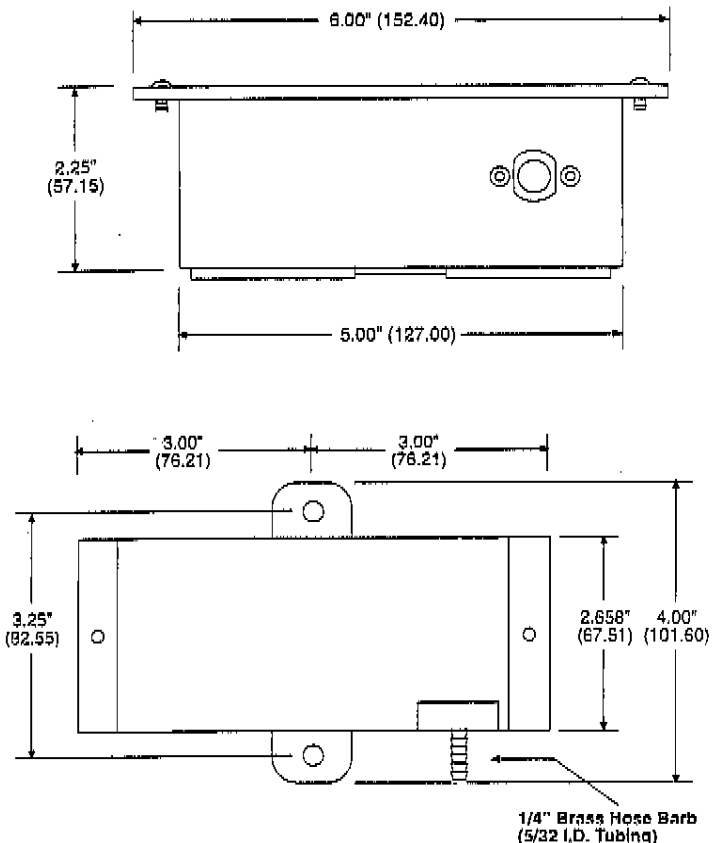

Figure-7 PR-243 Pressure Transducer Dimensions shown in inches and millimeters (mm).

For Technical / Application Assistance call your nearest office



MAMAC SYSTEMS®
MONITOR • DECISION • CONTROL

7400 Flying Cloud Drive • Minneapolis, MN 55344-3720 • USA
800-843-5116 • 952-835-1626 • Fax 952-829-5331
tech@mamacsys.com • www.mamacsys.com

EUROPE
Bald House, Units 6 & 7 Dudley Innovation Centre Pensnett Estate • Kingswinford West Midlands • DY8 8XZ United Kingdom 01384-271113 • Fax 01384-271114

AUSTRALIA
4 Armiger Court, Unit 2 Holden Hill • S. A. 5088 Australia 08-8359-4333 • Fax 08-8396-4433

ASIA
5611 North Bridge Road 03-08 • Eng Cheong Tower Singapore • 188782 65-3927273 • Fax 65-3927276

CANADA
155 McIntosh Drive, Unit 5 Markham • Ontario • L3R 0N6 Canada 905-474-9215 • Fax 905-474-0976

MAMAC Systems Inc. reserves the right to change any specifications without notice to improve performance, reliability, or function of our products.